

FIGHT AGAINST
COVID-19



Stay One-Step ahead of Infections
*Use Chrome **Touchless***

HAND SANITIZER DISPENSER

We know you love your family and want to provide the most advanced disinfection

C202



Led indicator



Water Tank



Easy to refill Liquid



Touchless sensor



Elegant Design



Product Features :

1. Intelligent :

Automatic sensor with microcomputer control, start work when your hands stretch to the unit and stop to work when the hands withdraw.

2. High efficiency :

Short time with simple operation, suitable for school, hospital, hotel, household and etc.

3. Energy-saving :

Ultrafine atomization without drip, which greatly saves the liquid disinfectant, and reduce the cost.

4. Hygiene :

Automatic sensing without contact, no cross-contamination.

IDEAL FOR



HOME



KINDERGARTEN

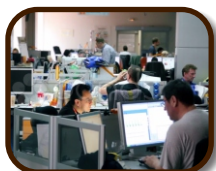

OFFICE



HOTEL



HOSPITALS



RESTAURANT

FIGHT AGAINST COVID-19

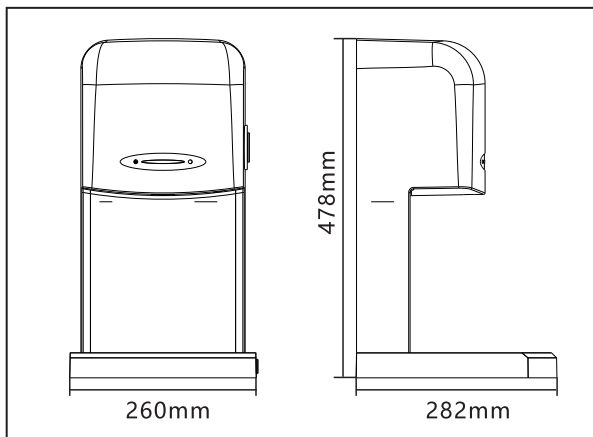
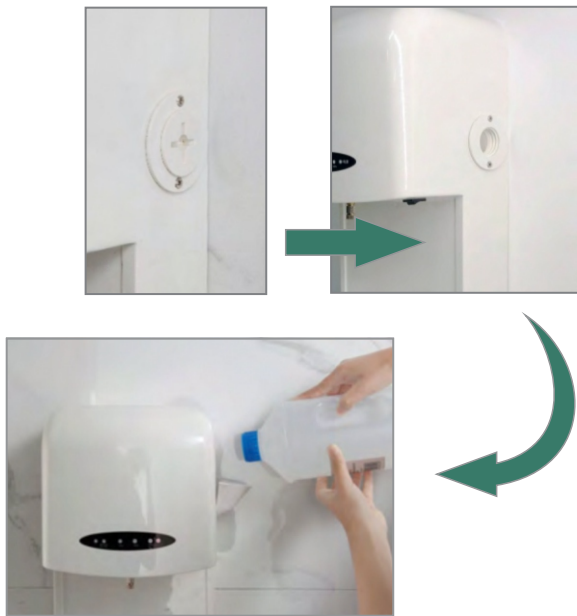

- Automatically sprays liquid by infrared sensor, suitable for use of various disinfectant liquids and hand sanitizer
- Automatic wall-mounted liquid soap dispenser of super large 2.3 L capacity
- Suitable for very high traffic facilities and for public use
- Designed with a plate to prevent water from dripping on the floor

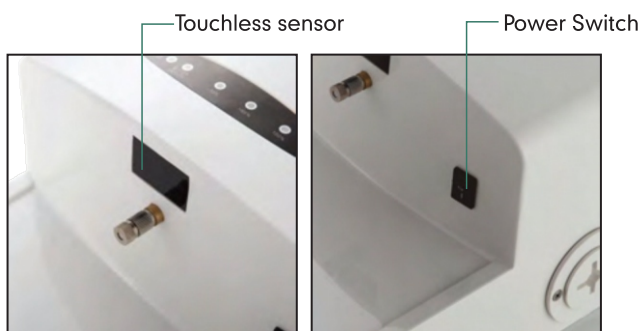

C 202

Power Supply	: 110V / 220V -- 240V -- 50 / 60Hz
Power	: 40W
Environmental Humidity	: ≤80%
Ambient Temperature	: 5-40
Storage Conditions	: Room Temperature, Clean Room
Spray Volume	: 0.6ml/s
Tank Capacity	: 2000ml
Sensing Distance	: 10 ± 3cm
Single Working Time limit	: ≤5seconds
Installation Mode	: Wall Mounted
Boundary Dimension	: 26 X 282 X 478 (mm)
Outer Package Size	: 685 X 648 X 545 (mm)
	(QTY : 4 GW : 16.4kg)
M.R.P. Rs.	: 15999/= (Per Pcs.) (Incl. of All Taxes)

Dealer & Distributor :

