

FIGHT AGAINST
COVID-19

 **Chrome**[®]
HAND SANITIZER

Best Touchless **HAND SANITIZER DISPENSER**

C101

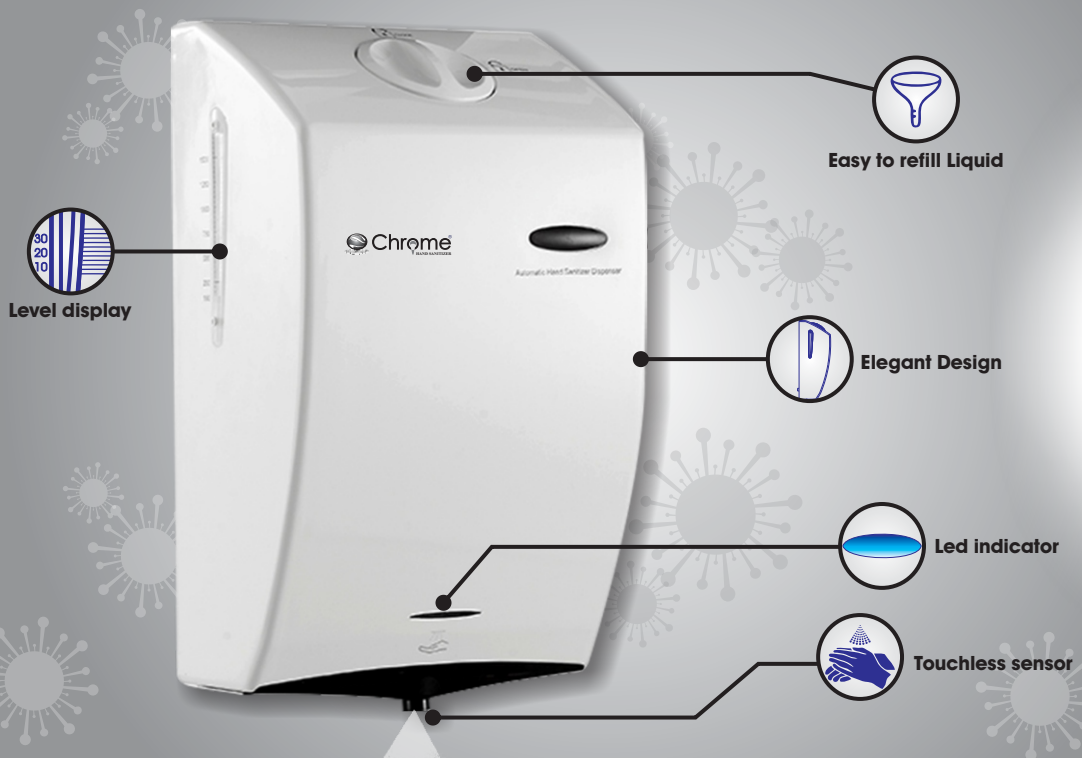

Elegant Design Features :

- ◆ 1. Infrared sensor controlled, touch-free operation to avoid pathogen cross-infection and re-contamination
- ◆ 2. Wide-angle spray nozzle to distribute liquid uniformly and perfectly
- ◆ 3. Easy installation & maintenance
- ◆ 4. Self-adjustable automatically sensing distance
- ◆ 5. Long life durable body : ABS Plastic
- ◆ 6. Suitable places: Hospital, food products factory, pharmaceutical factory, airport, restaurant, ETC...

IDEAL FOR



HOME



KINDERGARTEN

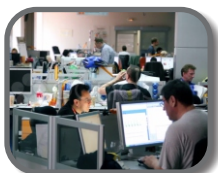

OFFICE



HOTEL



HOSPITALS



RESTAURANT

Best Touchless **HAND SANITIZER DISPENSER**



Automatic



Super Large Capacity



Touch-Free

Liquid Filling Method



- Automatically sprays liquid by infrared sensor, suitable for use of various disinfectant liquids and hand sanitizer
- Automatic wall-mounted liquid soap dispenser of super large 1.6 L capacity
- Suitable for high traffic facilities and for public use
- Level display located in the side of the dispenser. It constantly indicates the level of liquid available inside the dispenser
- Adjustable Spray volume from 0.6-10ml per use
- Easy to refill Liquid

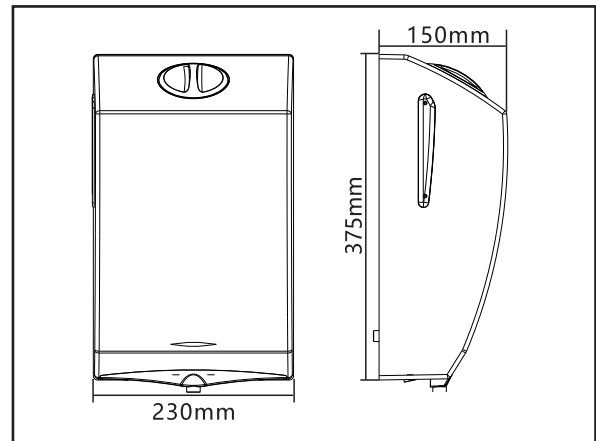

C101

Tank Capacity : 1600ml
 Sensing Distance : 10 ± 3cm
 Installation Mode : Wall Mounted
 Boundary Dimension : 230 X 150 X 375 (mm)
 Outer Package Size : 545 X 415 X 455 (mm)
 (QTY : 4, GW: 12kg)
 M.R.P. Rs. : 14999/= (Per Pcs.)
 (Incl. of All Taxes)

Dealer & Distributor :

